

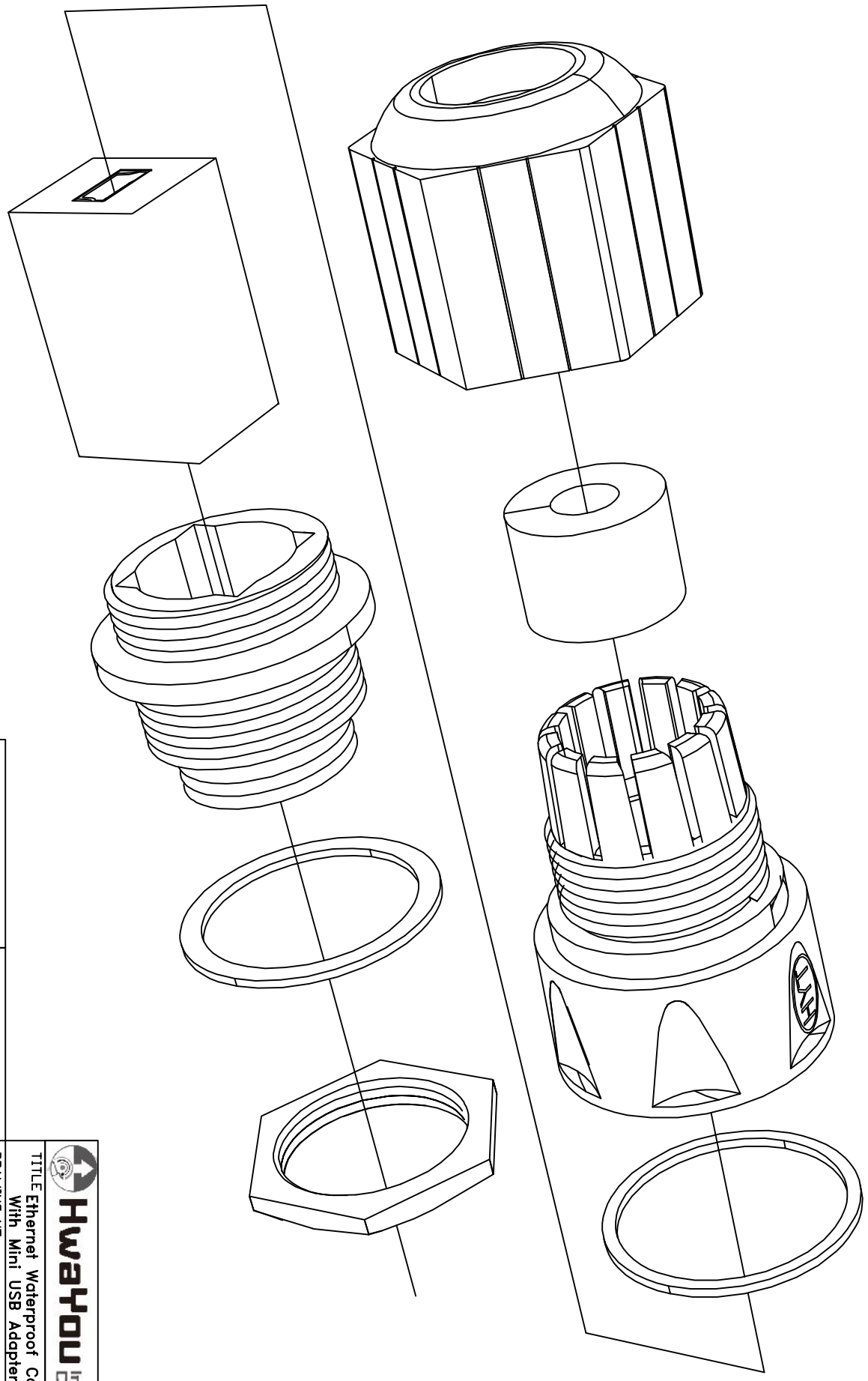

REV	DATE	DESCRIPTION	DRAWN



NOTE	DIMENSION
1. STRIP ALL BURRS.	UNLESS OTHERWISE
2. ALL DIMENSIONS ARE	NOTED TOLERANCES
3. DIAMETERS ON COMMON	0. X = ±0.2
CENTERS,	0. XX = ±0.1
TO BE CONCENTRIC	0. XXX = ±0.05
4. CHAMFER 1ST & LAST	
5. BREAK ALL CORNERS &	
EDGES CO.15 MAX.	

 Hwayou International Co., Ltd.	
TITLE Ethernet Waterproof Connector With Mini USB Adapter ASSY-1	
DRAWING NO.	HYUSB-S01-25.0
APPROVED	DRAWN DATE 08/07/10
CHECKED	SCALE 2:1
DRAWN	UNIT mm
ALICE	

REV	DATE	DESCRIPTION	DRAWN

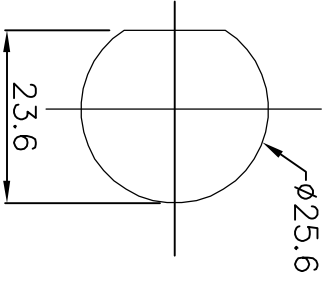
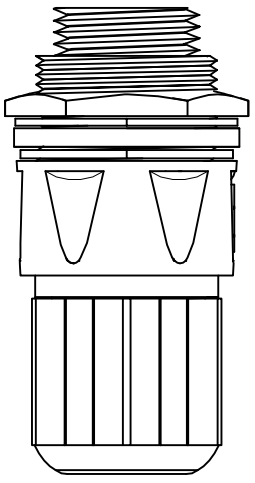
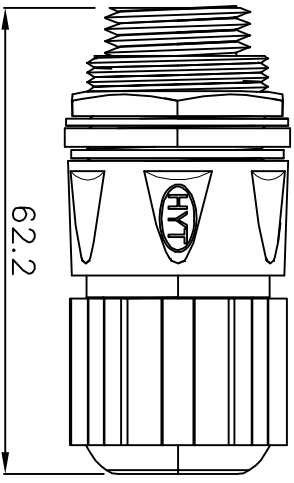
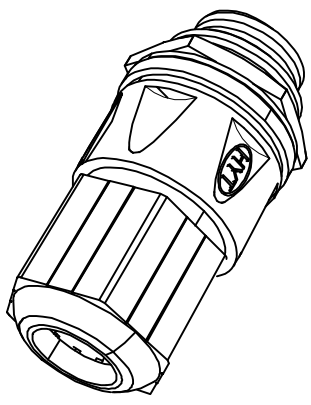

Hole dimension

NOTE	DIMENSION
1. STRIP ALL BURRS.	UNLESS OTHERWISE NOTED TOLERANCES 0. X = ± 0.2 0. XX = ± 0.1 0. XXX = ± 0.05
2. ALL DIMENSIONS ARE AFTER PLATING.	
3. DIAMETERS ON COMMON CENTERS TO BE CONCENTRIC WITHIN 0.1 T.I.R	
4. CHAMFER 1ST & LAST THREADS.	
5. BREAK ALL CORNERS & EDGES CO.15 MAX.	

 Hwayou International Co., Ltd.	
TITLE Ethernet Waterproof Connector With Mini USB Adapter ASST-2	
DRAWING NO.	HYUSB-S01-25.0
APPROVED	DRAWN DATE 08/07/10
CHECKED	SCALE 1:1
DRAWN	UNIT mm
ALICE	

REV	DATE	DESCRIPTION	DRAWN

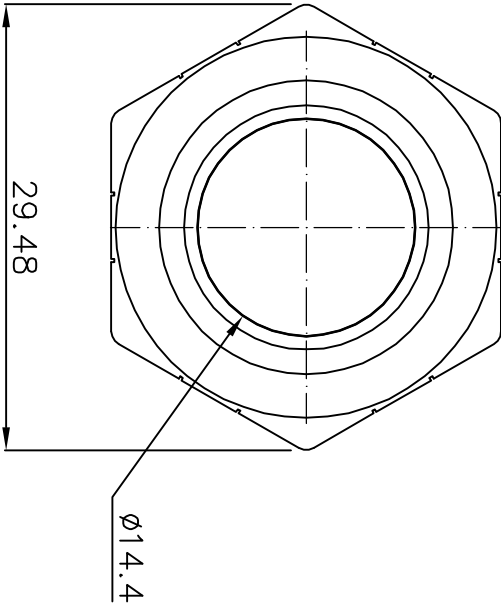
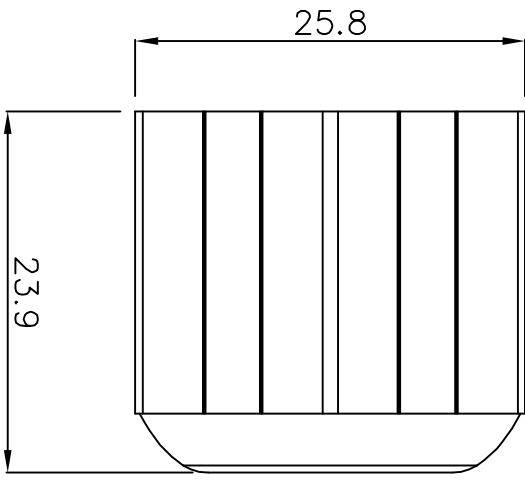

NOTE	DIMENSION
1. STRIP ALL BURRS.	UNLESS OTHERWISE NOTED TOLERANCES 0.X = ± 0.2 0.XX = ± 0.1 0.XXX = ± 0.05
2. ALL DIMENSIONS ARE AFTER PLATING.	
3. DIAMETERS ON COMMON CENTERS, TO BE CONCENTRIC WITHIN 0.1 T.I.R.	
4. CHAMFER 1.5 \times & LAST 1.5 \times & LAST	
5. BREAK ALL CORNERS & EDGES CO.15 MAX.	

TITLE WEC-Top Screw	
DRAWING NO. R1-0001	
APPROVED	DRAWN DATE 08/07/10
CHECKED	SCALE 2:1
DRAWN ALICE	UNIT mm

REV	DATE	DESCRIPTION	DRAWN
1			

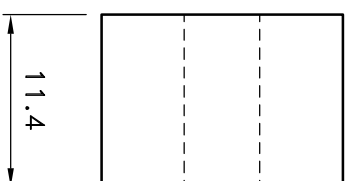
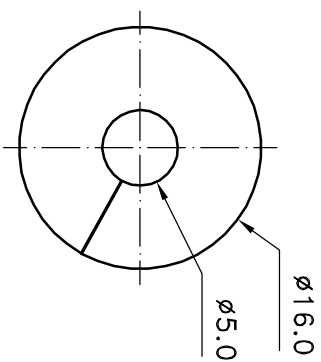

NOTE	DIMENSION
1. STRIP ALL BURRS. 2. ALL DIMENSIONS ARE AFTER PLATING. 3. DIAMETERS ON COMMON CENTERS. 4. CHAMFER 1ST & LAST HEADS WITHIN 0.1 T.I.R. 5. BREAK ALL CORNERS & EDGES CO.15 MAX.	UNLESS OTHERWISE NOTED TOLERANCES $X = \pm 0.3$ $0.X = \pm 0.2$ $0.XX = \pm 0.1$



Hwayou International Co., Ltd.

TITLE

WEC-Waterproof Washer

DRAWING NO.

R1-0013

APPROVED

DRAWN DATE
09/02/16

CHECKED

SCALE
2:1

DRAWN

ALICE

UNIT

mm

REV	DATE	DESCRIPTION	DRAWN

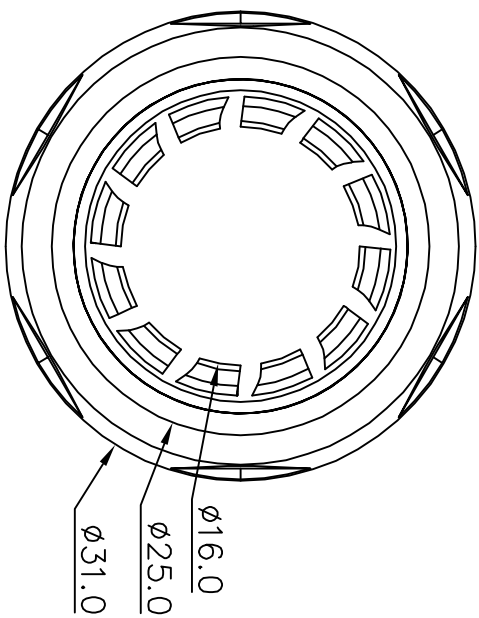
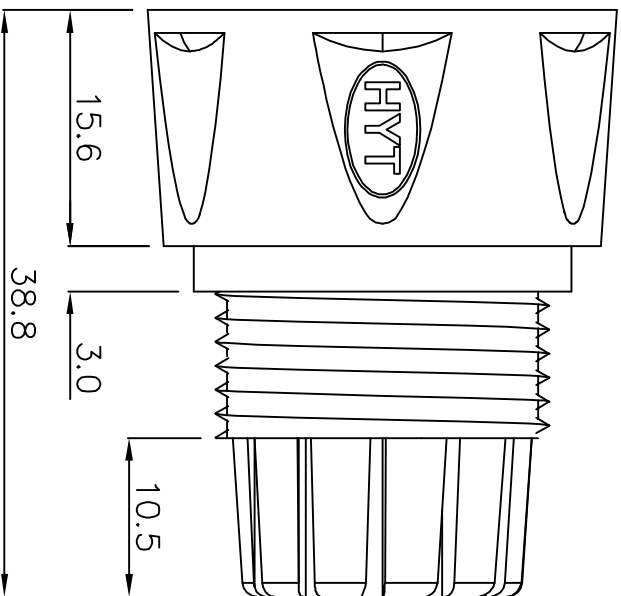

NOTE	DIMENSION
1. STRIP ALL BURRS.	UNLESS OTHERWISE NOTED TOLERANCES
2. ALL DIMENSIONS ARE AFTER PLATING.	0.X = ± 0.2
3. DIAMETERS ON COMMON CENTERS, TO BE CONCENTRIC WITHIN 0.1 T.I.R.	0.XX = ± 0.1
4. CHAMFER 1ST & LAST HEADS.	0.XXX = ± 0.05
5. BREAK ALL CORNERS & EDGES CO.15 MAX.	



Hwayou International Co., Ltd.

TITLE	WEC- Clip
DRAWING NO.	R1-0003
APPROVED	
CHECKED	
DRAWN	ALICE
DRAWN DATE	08/07/10
SCALE	2:1
UNIT	mm

REV	DATE	DESCRIPTION	DRAWN

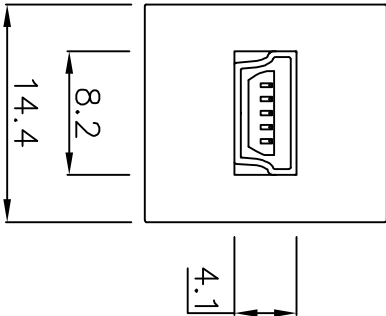
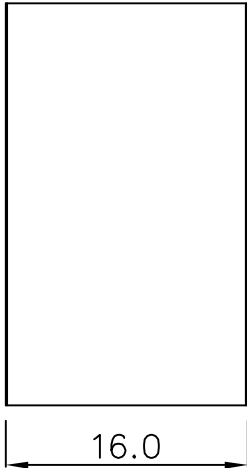
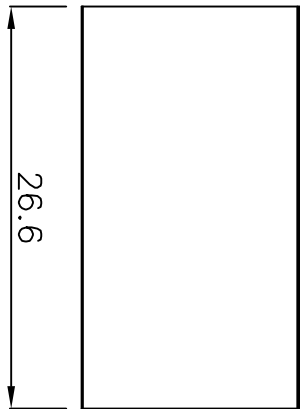
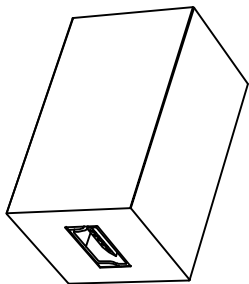

NOTE	DIMENSION
1. STRIP ALL BURRS. 2. ALL DIMENSIONS ARE AFTER PLATING. 3. DIAMETERS ON COMMON CENTERS, TO BE CONCENTRIC WITHIN 0.1 T.I.R. 4. CHAMFER 1ST & LAST THREADS. 5. BREAK ALL CORNERS & EDGES CO.15 MAX.	UNLESS OTHERWISE NOTED TOLERANCES 0.X = ±0.2 0.XX = ±0.1 0.XXX = ±0.05



Hwayou International Co., Ltd.

TITLE WEC-MINI USB Adapter	
DRAWING NO. UV-0001	
APPROVED	DRAWN DATE 08/07/10
CHECKED	SCALE 2:1
DRAWN ALICE	UNIT mm

REV	DATE	DESCRIPTION	DRAWN

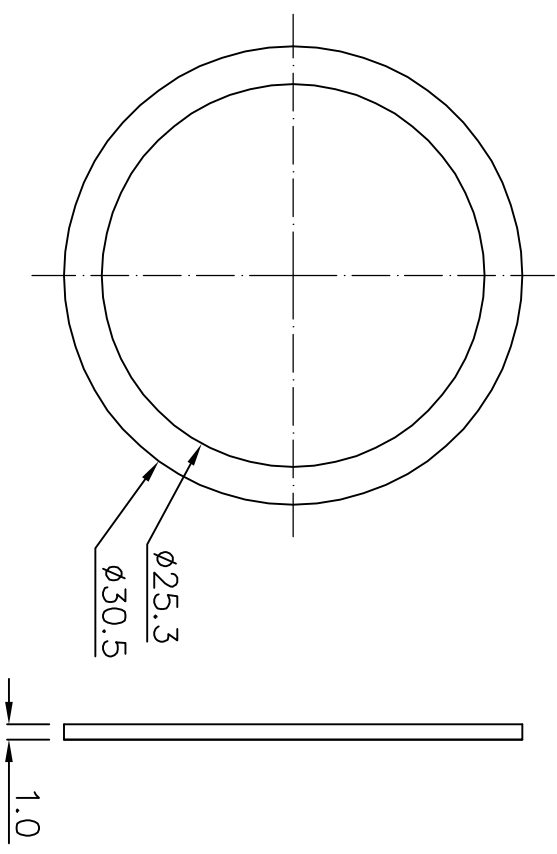

NOTE	DIMENSION
1. STRIP ALL BURRS.	UNLESS OTHERWISE NOTED TOLERANCES
2. ALL DIMENSIONS ARE AFTER PLATING.	0.X = ±0.2
3. DIAMETERS ON COMMON CENTERS.	0.XX = ±0.1
4. CHAMFER 1ST & LAST WITHIN 0.1 T.I.R.	0.XXX = ±0.05
5. BREAK ALL CORNERS & EDGES CO.15 MAX.	

 Hwayou International Co., Ltd.	
TITLE WEC-Waterproof Spacer 01	
DRAWING NO. R1-0006	DRAWN DATE 08/07/10
APPROVED	SCALE 2:1
CHECKED	UNIT mm
DRAWN ALICE	

REV	DATE	DESCRIPTION	DRAWN

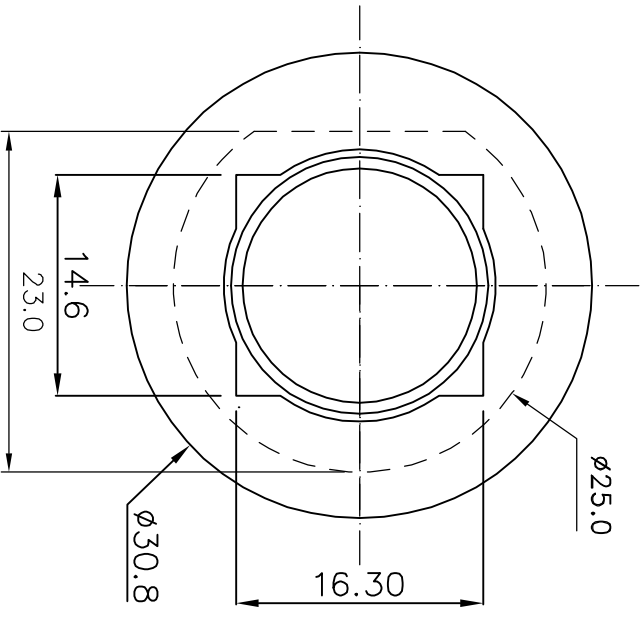
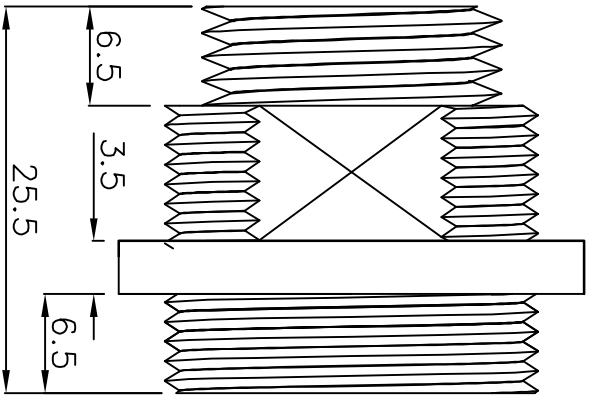

NOTE	DIMENSION
1. STRIP ALL BURRS.	UNLESS OTHERWISE
2. ALL DIMENSIONS ARE	NOTED TOLERANCES
3. DIAMETERS ON COMMON	0.X = ± 0.2
4. CHAMFER 1ST & LAST	0.XX = ± 0.1
5. BREAK ALL CORNERS &	0.XXX = ± 0.05

TITLE WEC-Body	
DRAWING NO. R1-0010	DRAWN DATE 08/07/10
APPROVED	SCALE 2:1
CHECKED	UNIT mm
DRAWN ALICE	

REV	DATE	DESCRIPTION	DRAWN

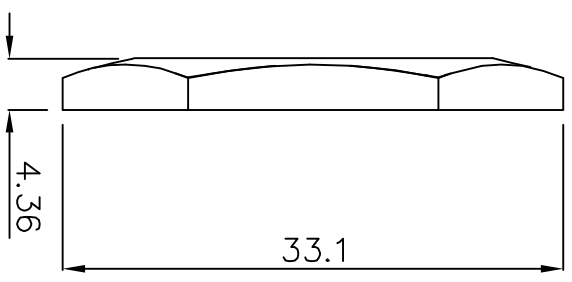
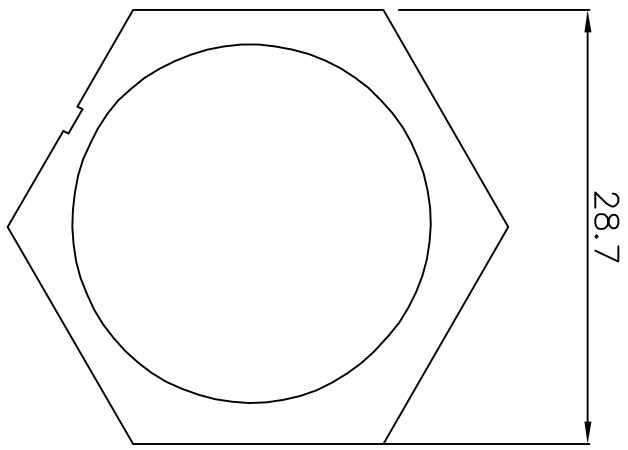

NOTE	DIMENSION
1. STRIP ALL BURRS.	UNLESS OTHERWISE NOTED TOLERANCES 0.X = ±0.2 0.XX = ±0.1 0.XXX = ±0.05
2. ALL DIMENSIONS ARE AFTER PLATING.	
3. DIAMETERS ON COMMON CENTERS TO BE CONCENTRIC WITHIN 0.1 T.I.R.	
4. CHAMFER 15° & LAST THREADS 45°	
5. BREAK ALL CORNERS & EDGES CO.15 MAX.	



TITLE
WEC-Nut

DRAWING NO.
R1-0007

APPROVED

CHECKED

DRAWN
ALICE

DRAWN DATE
08/07/10

SCALE
2:1

UNIT
mm